

S-SERIES

SCEC - SCWC - SCHPC

36" WIDE X 16"

SLIDE IN REPLACEMENT FOR:

RM Models - Cool Heat®, Islandaire®, ZoneAire®
Climate Master 702, 703 & 704 Models
 - Friedrich®, Weil-McLain®, ZoneAire®

SC Models - ZoneAire®, Applied Comfort®
SEA & SHA Models Heil-Quaker®, ZoneAire®
HQ, CM Models - Fedders Islandaire, Islandaire®
 Embassy® Weathertwin, TPI® Ra-Matic,
 Sears® 867 Models

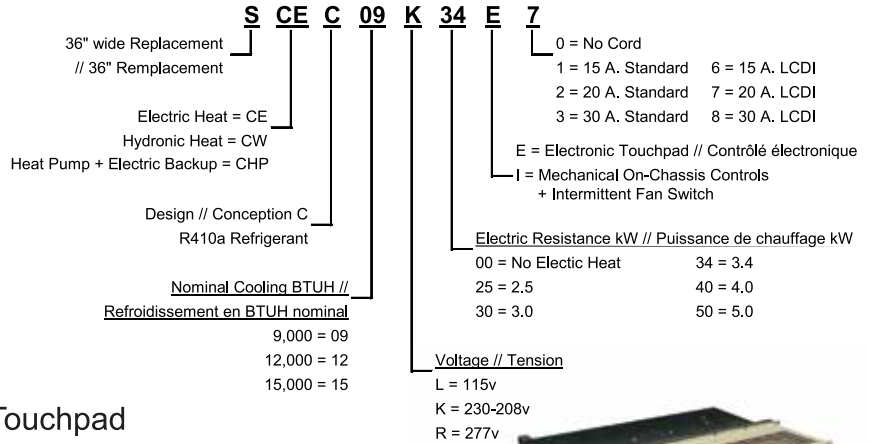

Mechanical Pushbutton (as shown)

- on-chassis controls
- selectable 3 speed room fan control
- mechanical control of fresh air door for up to 90 cfm
- on chassis temperature control
- no remote thermostat connection

Electronic Touchpad

- on-chassis touchpad with large LED readout
- switchable to 24v remote thermostats - EMS ready
- two speed room fan control
- electronic temperature limiting

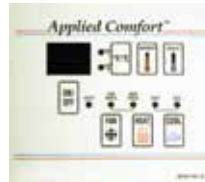

SCEC Air Conditioner with Electric Resistance Heat

SCWC Air Conditioner with Hydronic Heat

SCHPC Heat Pump with Electric Resistance Backup Heat

Model // Modèle	Voltage/	Hz	Cooling // Refroidissement				Reverse-Cycle Heat // Chauffage		Resistance Heat // Chauffage			Min. Circuit Amps	Fuse // Fusible Amps	Electrical Receptacle (NEMA)	Indoor CFM // Intérieur Pl.³/ min	** Vent CFM // événement Pl.³/ min	Net Wt. // Poids net lbs.	Ship Wt. // Poids net lbs.
			BTU/Hr.	EER	Amps	Pts./hr. // Chop./ hr.	BTU/ Hr.	COP	BTU/Hr.	kW	Amps							
SCEC09L00	115	60	9800	10.4	9.6	1.4	N/A	N/A	N/A	N/A	N/A	13	15	#5-15R	450	90	118	127
SCEC12L00	"	"	11800	9.5	11.5	2.2	N/A	N/A	N/A	N/A	N/A	16.2	20	#5-20R	"	"	119	128
SCEC09K25	230/208	"	9800	10.4	4.8/5.3	1.4	N/A	N/A	8900/7300	2.5/2.1	11.6/10.5	14.4	20	#6-20R	"	"	118	127
SCEC12K34	"	"	11800	9.5	6.5/7.1	2.2	N/A	N/A	12000/9900	3.4/2.8	15.5/14.1	19.3	20	#6-20R	"	"	119	128
SCEC15K50	"	"	14400	9.4	7.5/8.2	3.9	N/A	N/A	17400/14300	5/4.1	22.5/20.4	28	30	#6-30R	"	"	120	129
SCEC09R20	277	"	9800	10.4	4	1.4	N/A	N/A	7200	2.0	8	9.9	15	#7-20R	"	"	118	127
SCEC12R30	"	"	11800	9.5	5.4	2.2	N/A	N/A	10600	3.0	11.6	14.4	15	#7-20R	"	"	119	128
SCEC15R40	"	"	14400	9.4	6.3	3.9	N/A	N/A	14000	4.0	15.2	19	20	#7-20R	"	"	120	129
SCWC09L00	115	"	9800	10.4	9.2	1.4	N/A	N/A	N/A	N/A	N/A	12.6	15	#5-15R	"	"	118	127
SCWC12L00	"	"	11800	9.5	11.6	2.2	N/A	N/A	N/A	N/A	N/A	16.2	20	#5-20R	"	"	119	128
SCWC09K00	230/208	"	9800	10.4	4.5/4.7	1.4	N/A	N/A	N/A	N/A	N/A	6.4	15	#6-20R	"	"	118	127
SCWC12K00	"	"	11800	9.5	6.5/7.1	2.2	N/A	N/A	N/A	N/A	N/A	8.1	15	#6-20R	"	"	119	128
SCWC15K00	"	"	14400	9.4	7.5/8.2	3.9	N/A	N/A	N/A	N/A	N/A	9.6	15	#6-20R	"	"	120	129
SCWC09R00	277	"	9800	10.4	4	1.4	N/A	N/A	N/A	N/A	N/A	5.8	15	#7-20R	"	"	118	127
SCWC12R00	"	"	11800	9.5	5.4	2.2	N/A	N/A	N/A	N/A	N/A	6.8	15	#7-20R	"	"	119	128
SCWC15R00	"	"	14400	9.4	6.3	3.9	N/A	N/A	N/A	N/A	N/A	8.4	15	#7-20R	"	"	120	129
SCHPC12K00	230/208	"	11800	9.5	5.9/6.2	2.2	12300	3.3	N/A	N/A	N/A	8.1	15	#6-20R	"	"	125	134
SCHPC12K25	"	"	11800	9.5	5.9/6.2	2.2	12300	3.3	8900/7300	2.5/2.1	11.6/10.5	14.5	15	#6-20R	"	"	125	134
SCHPC15K34	"	"	14400	9.4	7.6/8.0	3.9	15200	3.1	12000/9900	3.4/2.8	15.5/14.1	19.3	20	#6-20R	"	"	126	135
SCHPC15K50	"	"	14400	9.4	7.6/8.0	3.9	15200	3.1	17400/14300	5/4.1	22.5/20.4	28	30	#6-30R	"	"	126	135
SCHPC12R20	277	"	11800	9.5	4	2.2	12300	3.3	10600	3.0	11.6	14.4	15	#7-20R	"	"	125	134
SCHPC12R30	"	"	11800	9.5	5.4	2.2	12300	3.3	10600	3.0	11.6	14.4	15	#7-20R	"	"	126	135
SCHPC15R40	"	"	14400	9.4	6.7	3.9	15200	3.1	14000	4.0	15.2	19	20	#7-20R	"	"	126	135

Other heater sizes and cooling only models are available. Consult our website, or contact us directly for further information.

** Vent fresh air is only available on chassis with mechanical controls; there is no vent air on chassis with Electronic controls.

HIGHEST EFFICIENCY

www.ptacs.com

HIGHEST RELIABILITY